

MATERIAL

Glass-fibre reinforced polyamide based (PA) technopolymer, grey-black colour, matte finish.

STANDARD EXECUTION

Brass boss, cylindrical blind hole, transversal semi-machined hole for pinning to shaft.

Revolving handle 1.741+x (see page 502) in technopolymer.

The grooves cut into the cylindrical surface allow an effective and ergonomic grip, though necessarily limited to the fingertips, due to the small size of the handle.



ELESA Original design **ERGOSTYLE®**

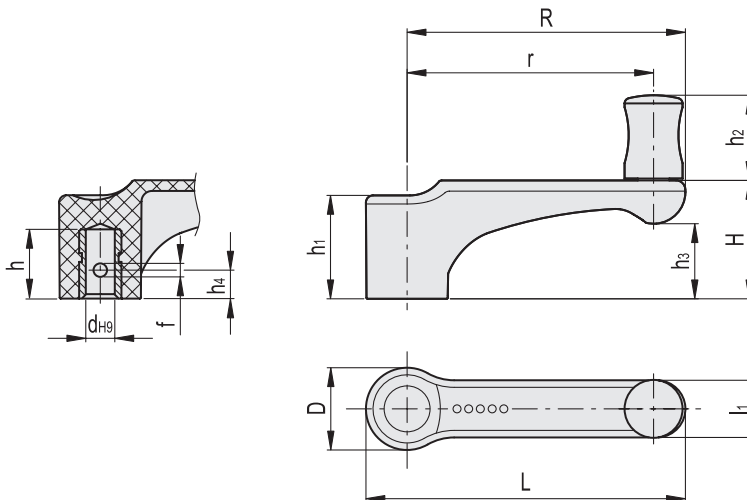

Conversion Table
1 mm = 0.039 inch

R	
mm	inch
44	1.73
63	2.48
78	3.07

Code	Description	R	dh9	L	D	l1	h	h1	h2	h3	h4	H	r	f	⚖️
232411-C1	ERFW.44 N-6+I-C1	44	6	52	15.5	11	15	19	20	13	7	21	38	3	18
232431-C1	ERFW.63 N-8+I-C1	63	8	73.5	19	13.5	20	24.5	23	18	8	28.5	56	4	28
232451-C1	ERFW.78 N-10+I-C1	78	10	90.5	23	16	25	29.5	23	21	9	30	71	4	43

- 1
- 2
- 3
- 4
- 5
- 6
- 7
- 8
- 9
- 10
- 11
- 12
- 13
- 14
- 15
- RH

METRIC

Operating elements